

NOTES: UNLESS OTHERWISE SPECIFIED

1. SEE DRAWING NO. CB-00290 AND PROCEDURE P-1000 FOR ASSEMBLY AND TEST INSTRUCTION. PROCEDURES AND ASSEMBLY DRAWINGS ARE FOR INTERNAL USE ONLY.
2. ALL TESTING IS PERFORMED IAW BATTERY COUNCIL INTERNATIONAL STANDARDS.
3. ALL DIMENSIONS ARE INCH [MM]
4. ABBREVIATION USED IN TITLE IS: SEALED LEAD ACID (SLA)

REVISIONS			
REV	DESCRIPTION	DATE	APPROVED
A	REDESIGNED COVER	12/19/17	PH

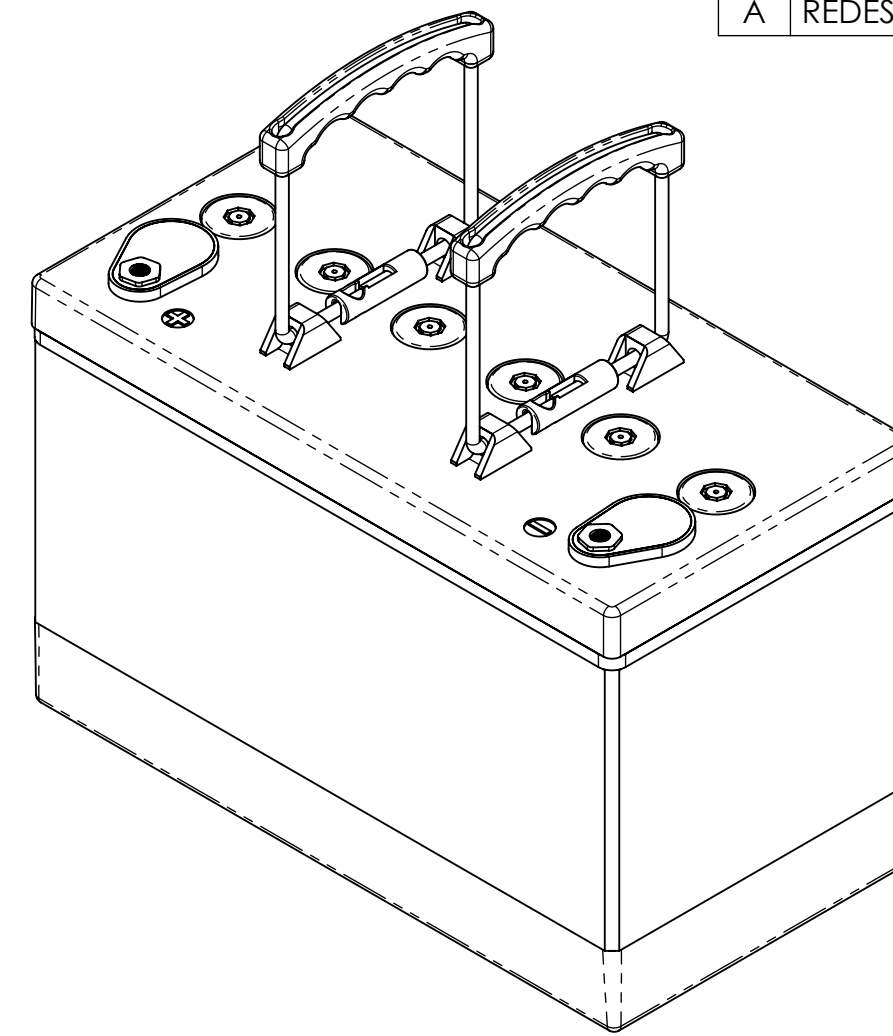

ISOMETRIC VIEW

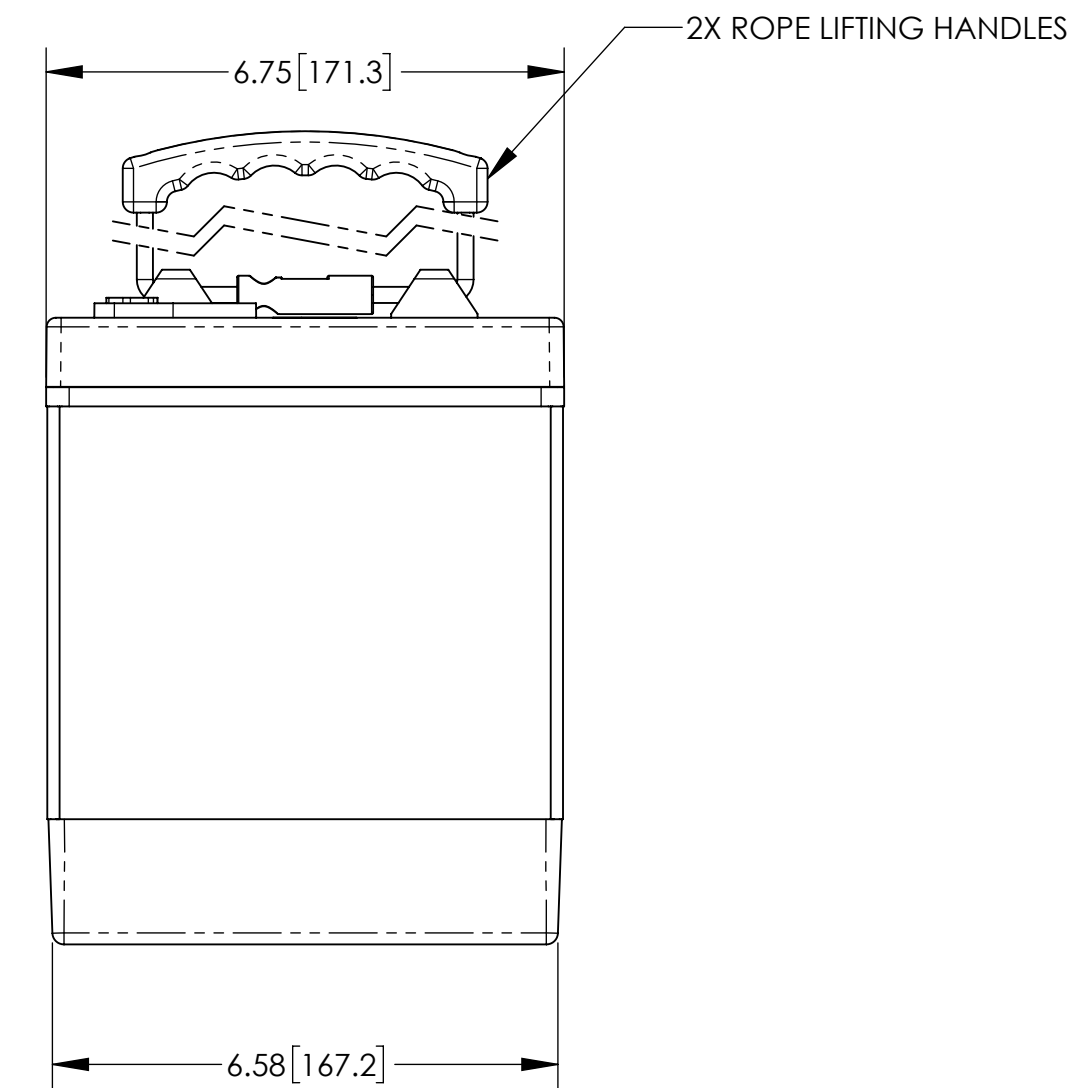
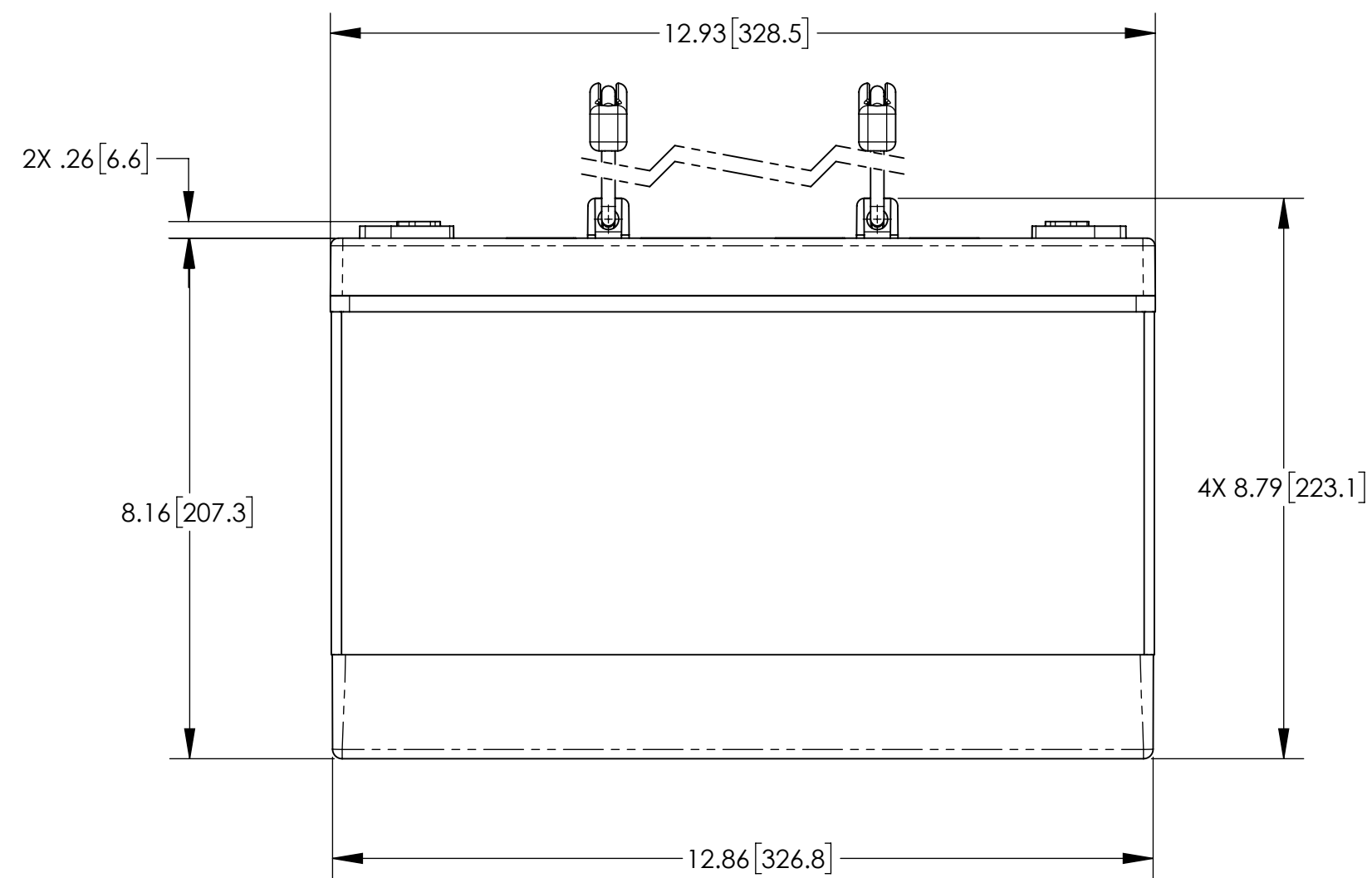
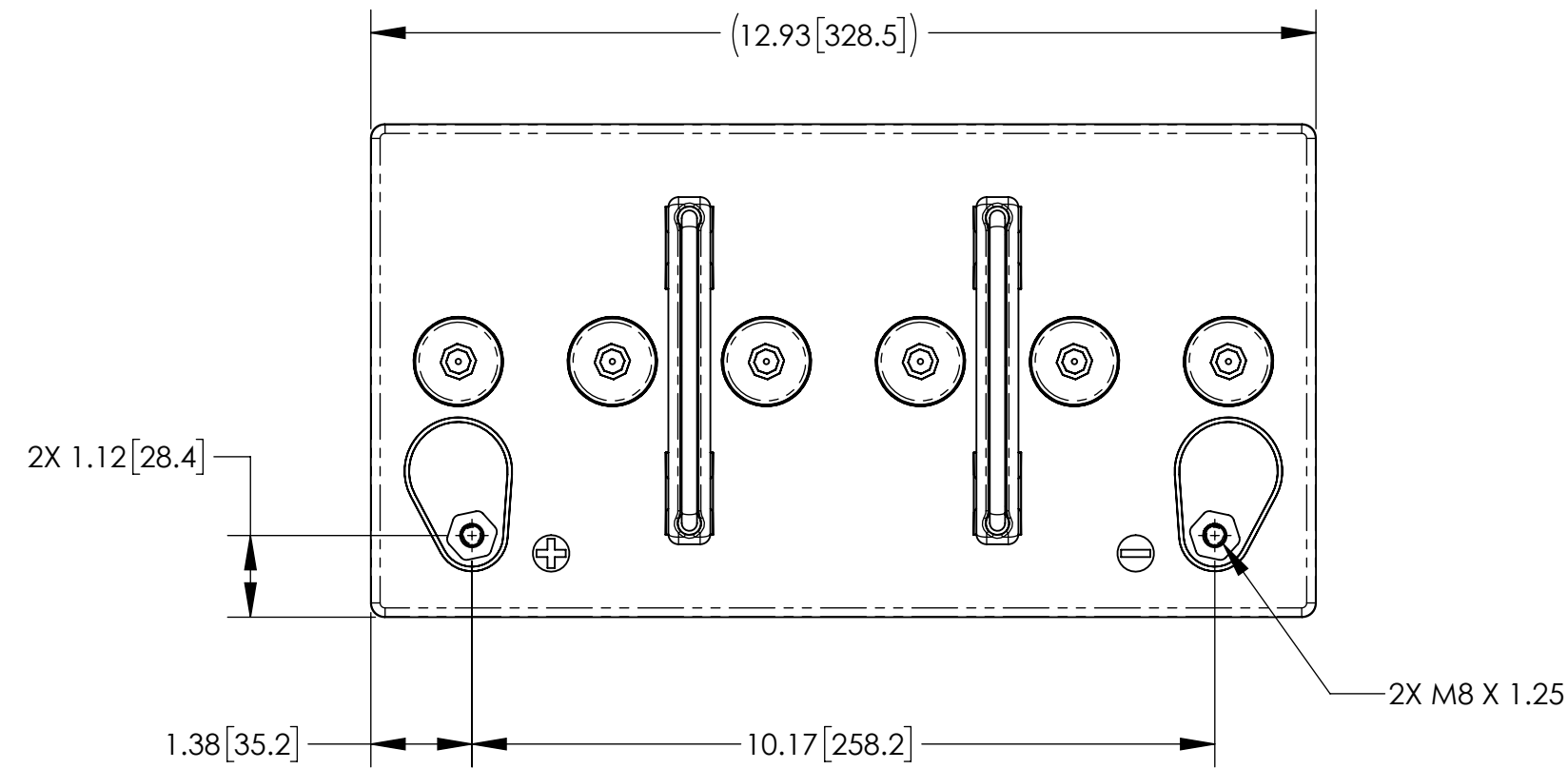

ENVELOPE DRAWING

CAPACITY RATINGS	
PART NUMBER	PVX-1290T
NOMINAL WEIGHT	75 LBS [34.0 KG]
AMPERE HOUR CAPACITY @ 24 HOUR 1.75 VOLTS/CELL @ 77°F (25°C)	129 AH

UNLESS OTHERWISE SPECIFIED DIMENSIONS ARE IN INCHES TOLERANCES ARE:			CONTRACT NO.		CONCORDE BATTERY CORPORATION 2009 SAN BERNARDINO RD, W. COVINA, CA 91790				
FRACTIONS	DECIMALS	ANGLES	APPROVALS	DATE	TITLE				
±1/32	.XX ± .06 .XXX ± .030	±1°	DRAWN	D. AYALA	5/13/11	BATTERY, SLA, 12 VOLT, PVX-1290T			
TREATMENT	NONE		CHECKED	AMIII	5/16/11	SIZE	CAGE CODE	DWG NO.	REV
FINISH	NONE		APPROVED	DV	5/17/11	C	63017	PVX-1290T	A
SIMILAR TO	CALC WT		ISSUED	JG	12/19/17	SCALE	1:2.5		SHEET 1 OF 1