

NOTES: UNLESS OTHERWISE SPECIFIED

1. SEE DRAWING NO. CB-00279 AND PROCEDURE P-1000 FOR ASSEMBLY AND TEST INSTRUCTION. PROCEDURES AND ASSEMBLY DRAWINGS ARE FOR INTERNAL USE ONLY.
2. ALL TESTING ARE IAW BATTERY COUNCIL INTERNATIONAL STANDARDS.
3. ALL DIMENSIONS ARE IN INCHES [MM].

REVISIONS			
REV	DESCRIPTION	DATE	APPROVED
A	REMOVED TERMINAL PROTECTORS	8/30/06	JBT

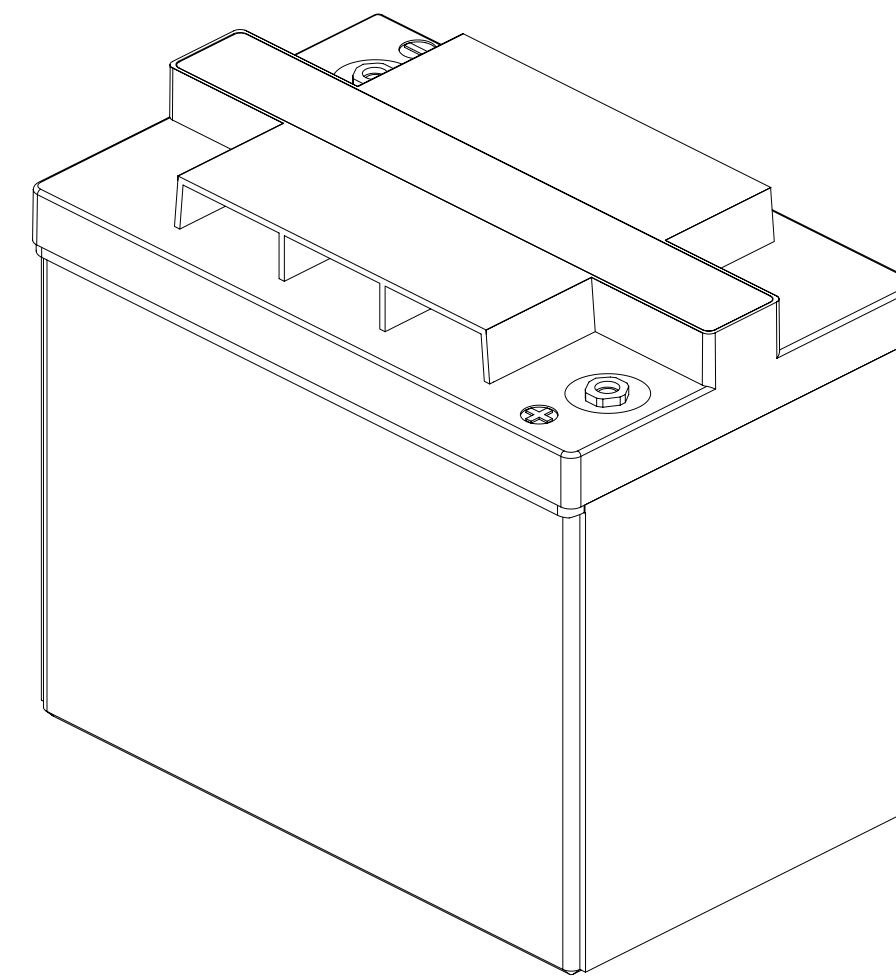
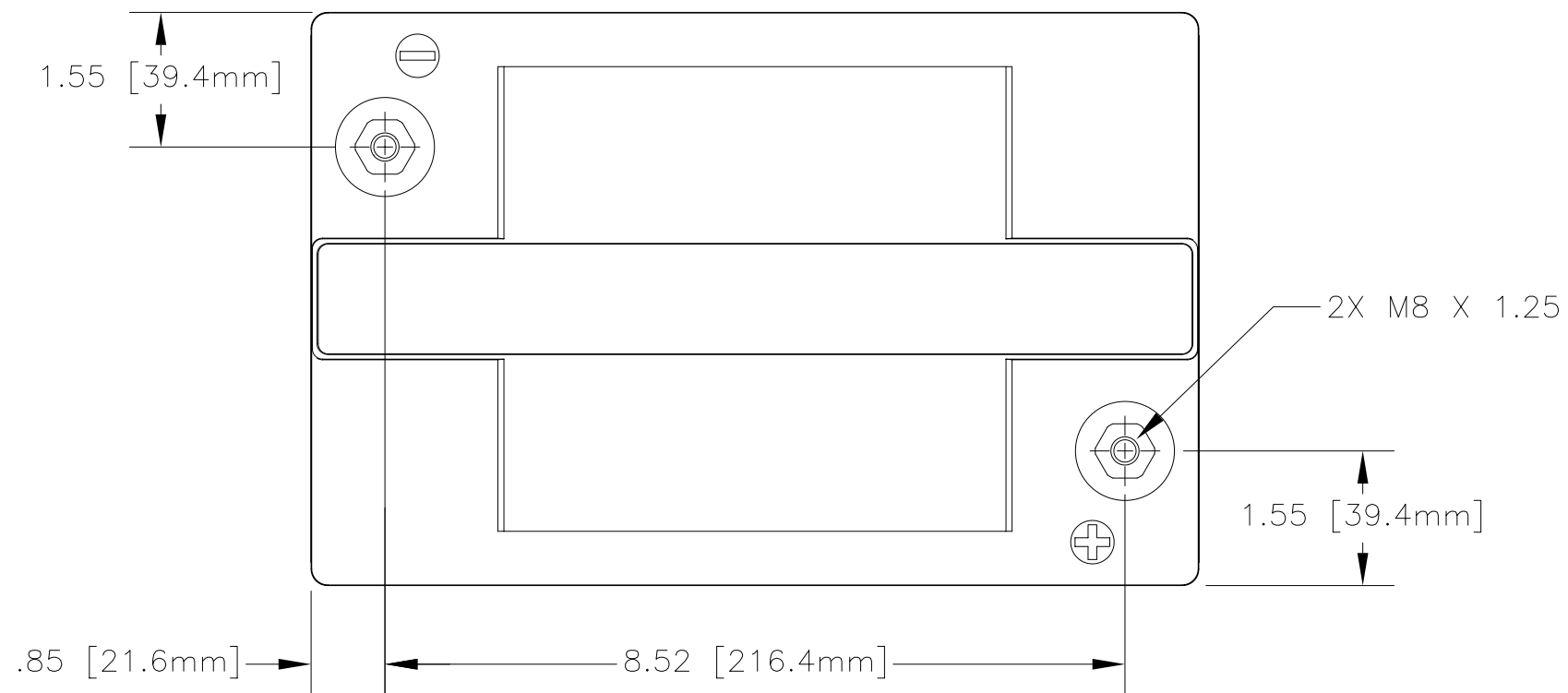

REFERENCE VIEW

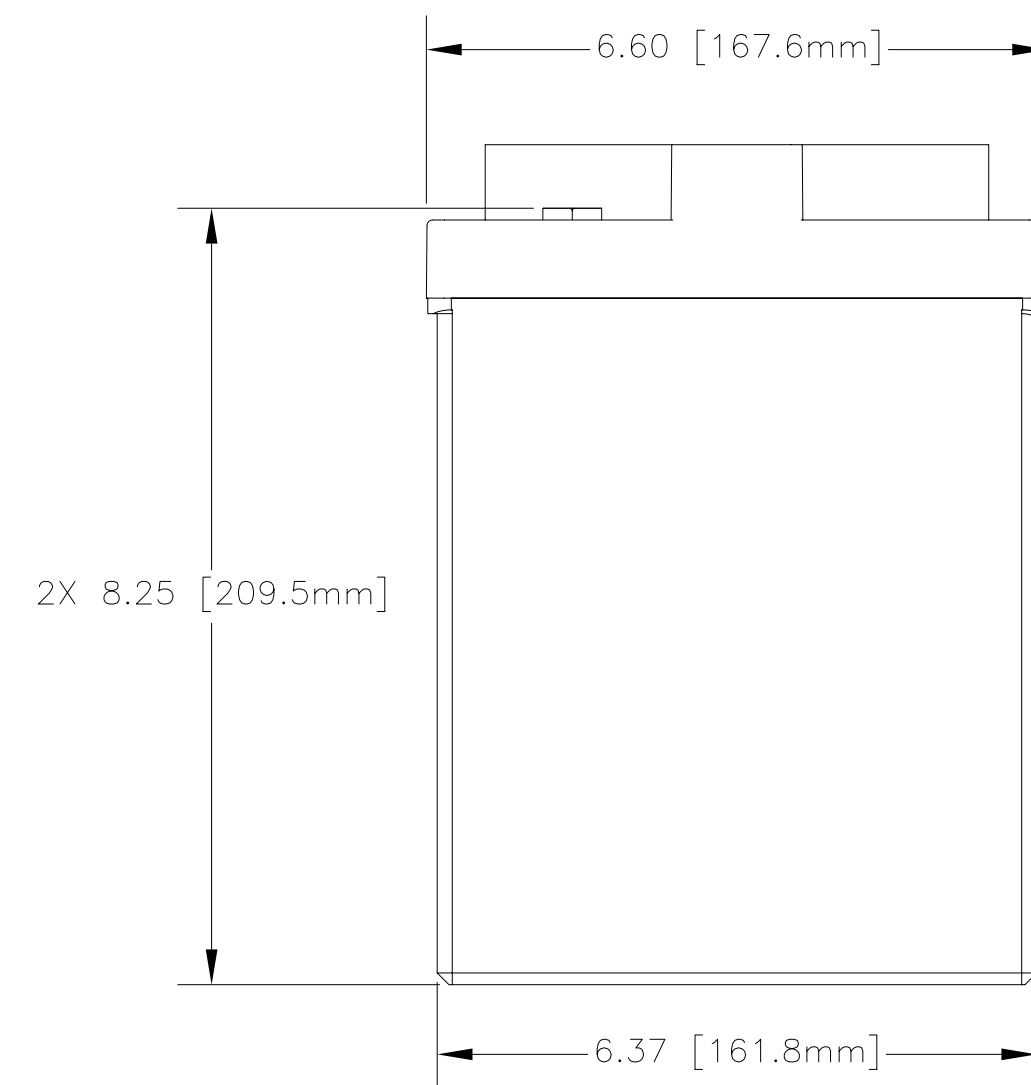
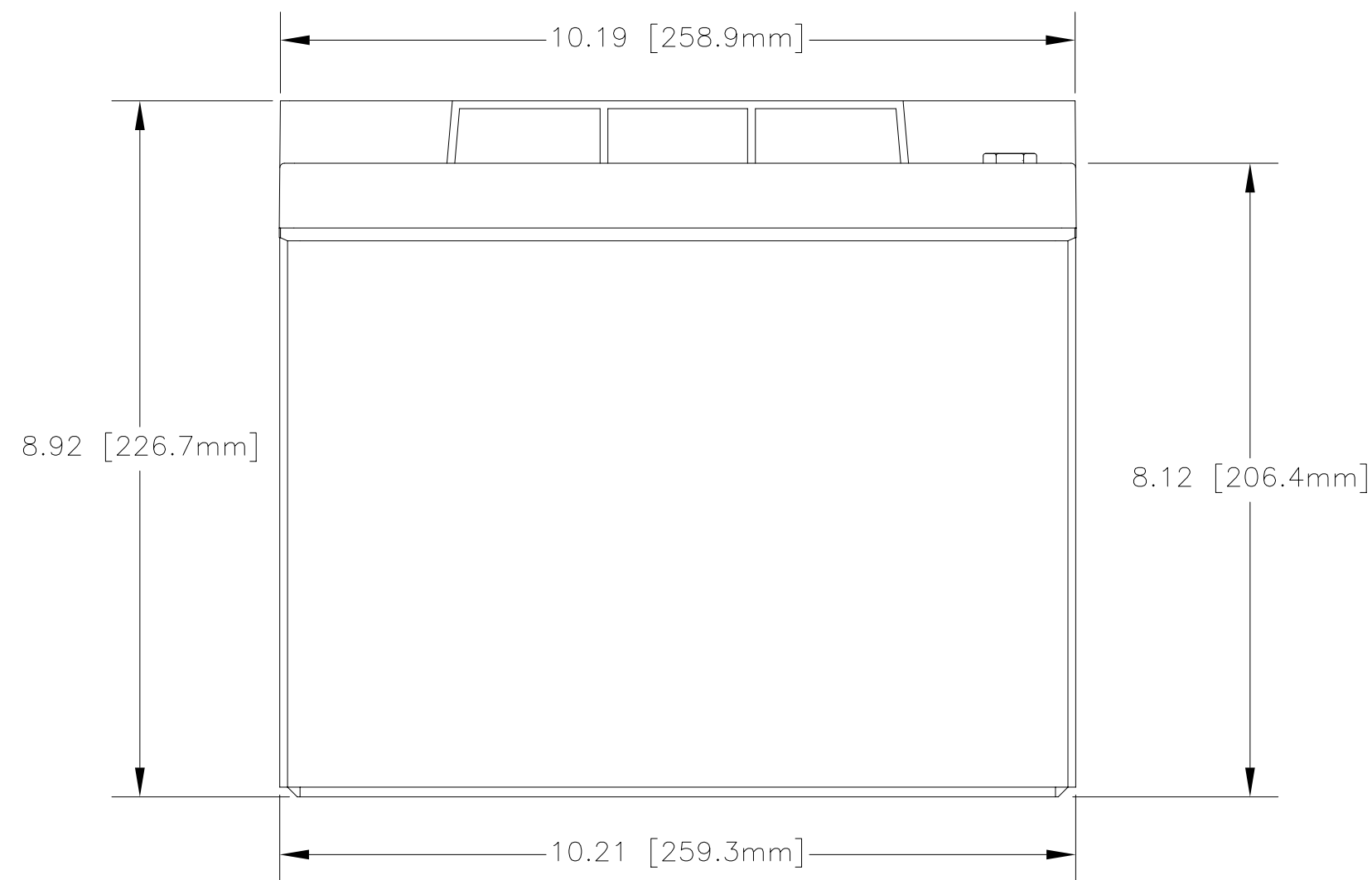

ENVELOPE DRAWING

CAPACITY RATINGS	
PART NUMBER	PVX-1030T
NOMINAL WEIGHT	42 LBS [19.1 KG]
AMPERE HOUR CAPACITY @ 24 HOUR 1.75 VOLTS/CELL @ 77°F (25°C)	103 AH

QTY REQD	CAGE CODE	PART OR IDENTIFYING NO.	NOMENCLATURE OR DESCRIPTION	MATERIAL SPECIFICATION	ITEM NO.
PARTS LIST					
UNLESS OTHERWISE SPECIFIED DIMENSIONS ARE IN INCHES. TOLERANCES ARE: FRACTIONS DECIMALS ANGLES ± 1/32 .XX ± .06 ± 1° .XXX ± .030			CONTRACT NO.	CONCORDE BATTERY CORPORATION 2009 SAN BERNARDINO RD, W. COVINA, CA 91790	
TREATMENT NONE			APPROVALS	DATE	TITLE
FINISH NONE			DRAWN A. MISTRETTA	9/27/05	BATTERY, SLA, 6 VOLT, PVX-1030T
SIMILAR TO NA			CHECKED AMIII	9/28/05	SIZE CAGE CODE
ACT WT NA CALC WT NA			APPROVED JBT	9/28/05	DWG NO. PVX-1030T
			ISSUED NS	9/5/06	REV A
				SCALE NONE	SHEET 1 OF 1

ENGINEERING COPY 05SEP06