

NOTES: UNLESS OTHERWISE SPECIFIED

1. SEE DRAWING NO. CB-00391 AND PROCEDURE P-1000 FOR ASSEMBLY AND TEST INSTRUCTIONS. PROCEDURES AND ASSEMBLY DRAWING ARE FOR INTERNAL USE ONLY.
2. ALL TESTING IS PERFORMED IAW BATTERY COUNCIL INTERNATIONAL STANDARDS.
3. ALL DIMENSIONS ARE IN INCHES [MILLIMETERS].

REVISIONS			
REV	DESCRIPTION	DATE	APPROVED

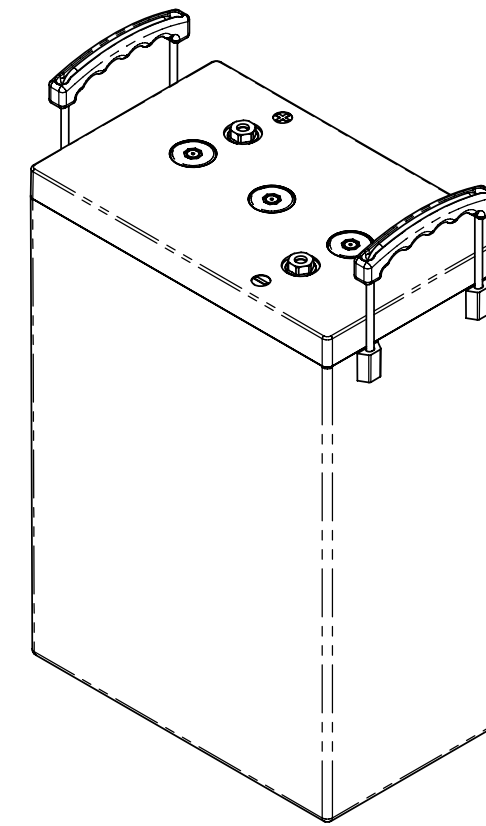
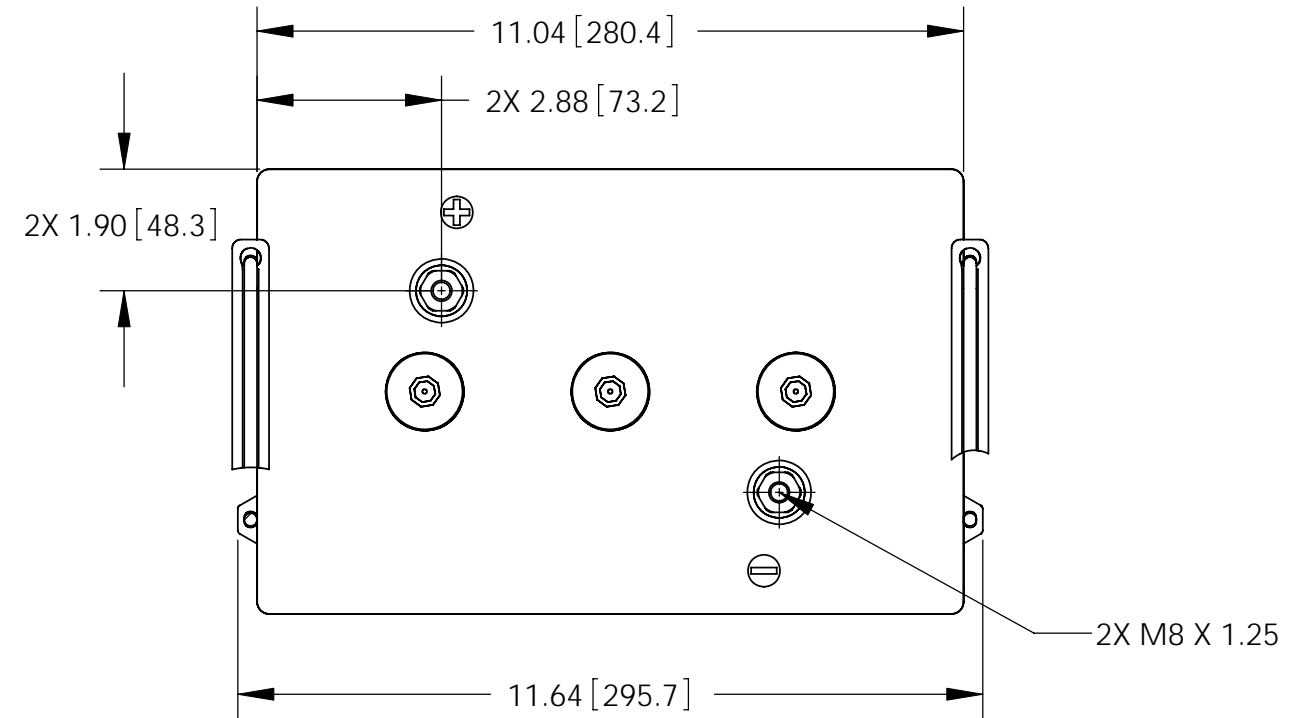

REFERENCE VIEW

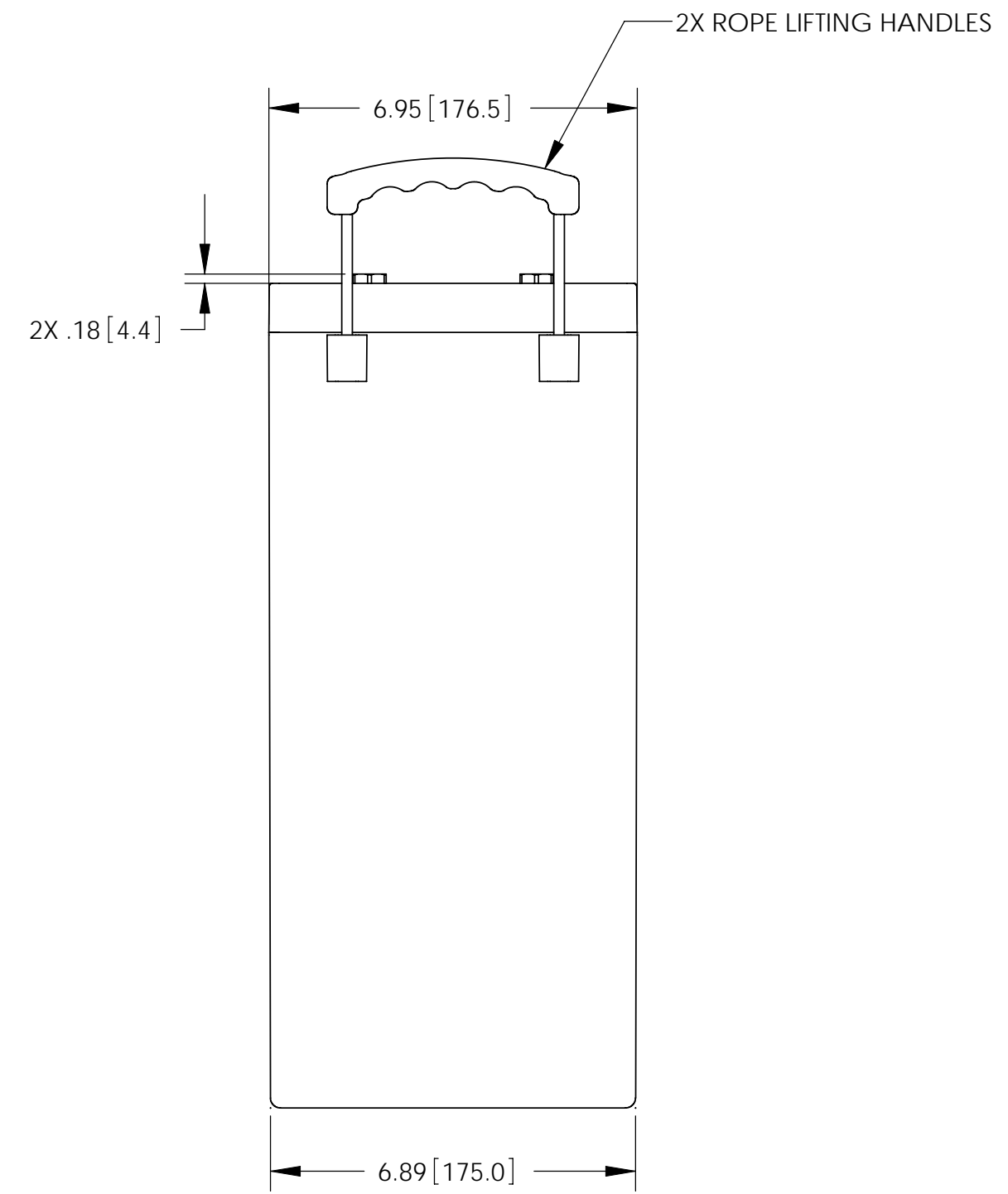
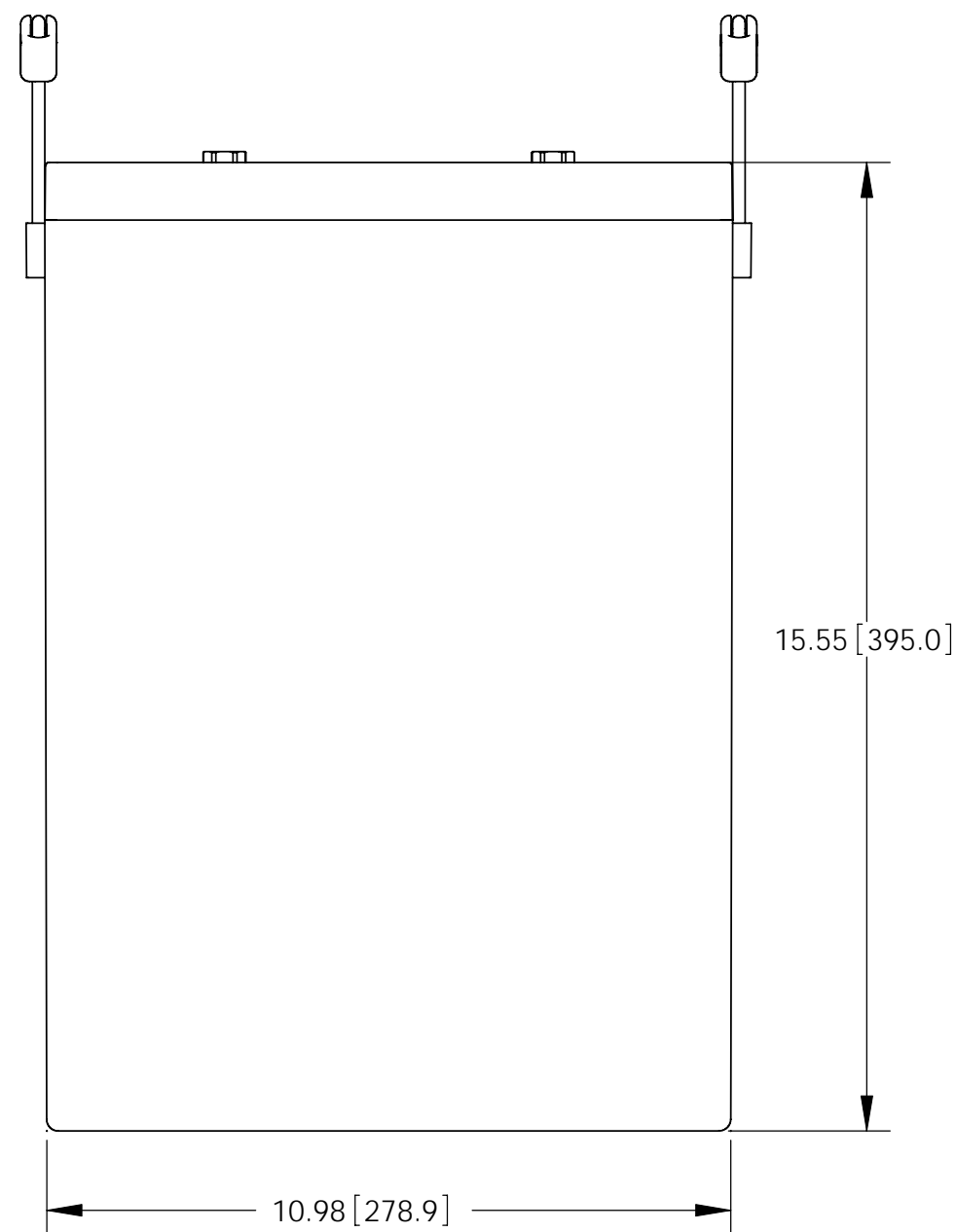

ENVELOPE DRAWING

CAPACITY RATINGS	
PART NUMBER	AGM-6400HT
NOMINAL WEIGHT	119 LBS [54.0 KG]
AMPERE HOUR CAPACITY @ 20 HOUR 1.75 VOLTS/CELL @ 77 °F (25 °C)	400 AH
MINUTES OF DISCHARGE @ 25 AMPS 1.75 VOLTS/CELL @ 77 °F (25 °C)	950 MIN

UNLESS OTHERWISE SPECIFIED DIMENSIONS ARE IN INCHES TOLERANCES ARE:			CONTRACT NO.		CONCORDE BATTERY CORPORATION 2009 SAN BERNARDINO RD, W. COVINA, CA 91790				
FRACTIONS	DECIMALS	ANGLES	APPROVALS	DATE	TITLE				
±1/32	.XX ± .12 .XXX ± .060	±1°	DRAWN	N.SANCHEZ	6/29/09	BATTERY, 6 VOLT, AGM-6400HT			
TREATMENT	NONE	CHECKED	AMIII	7/6/09	SIZE	CAGE CODE	DWG NO.	REV	
FINISH	NONE	APPROVED	JBT	7/7/09	C	63017	AGM-6400HT		
SIMILAR TO	CALC WT	ISSUED	JJ	7/8/09	SCALE	1:3	SHEET 1 OF 1		